

FG-NS-4-00 Fats & Grease Trap designed to IS EN 1825 Volume 1,450 lit

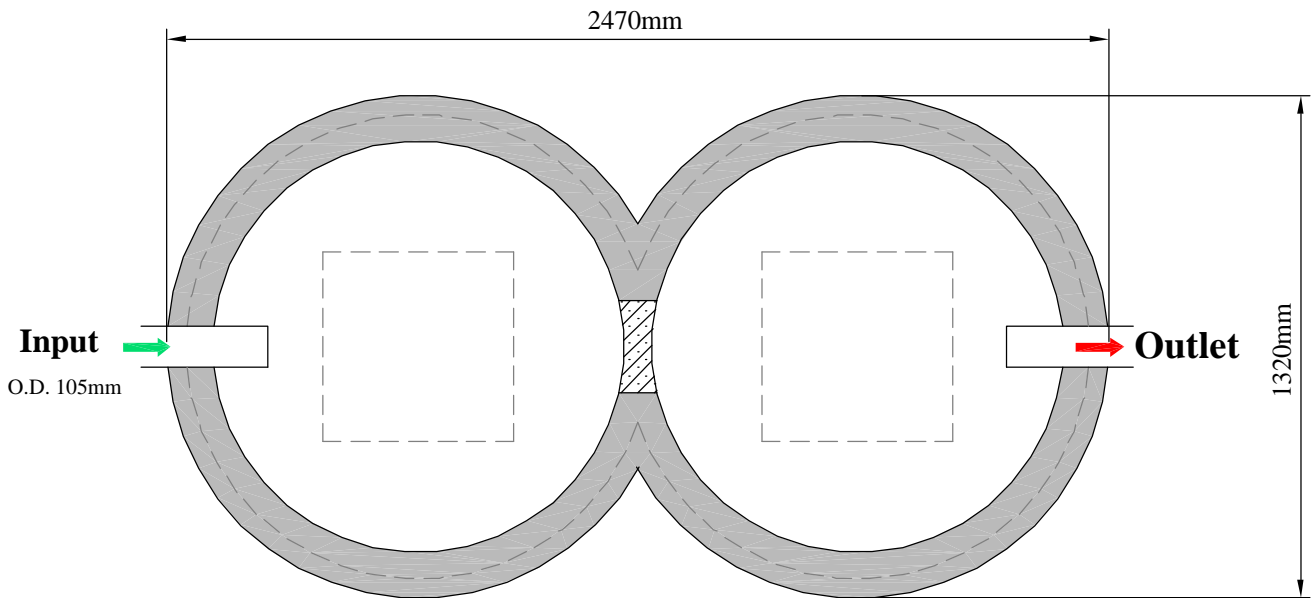

4 l/s nominal flow @ >60C
300 lit. Grease retention
300 lit. sludge capacity

An anti-syphon vent
 is required for long
 run outflows

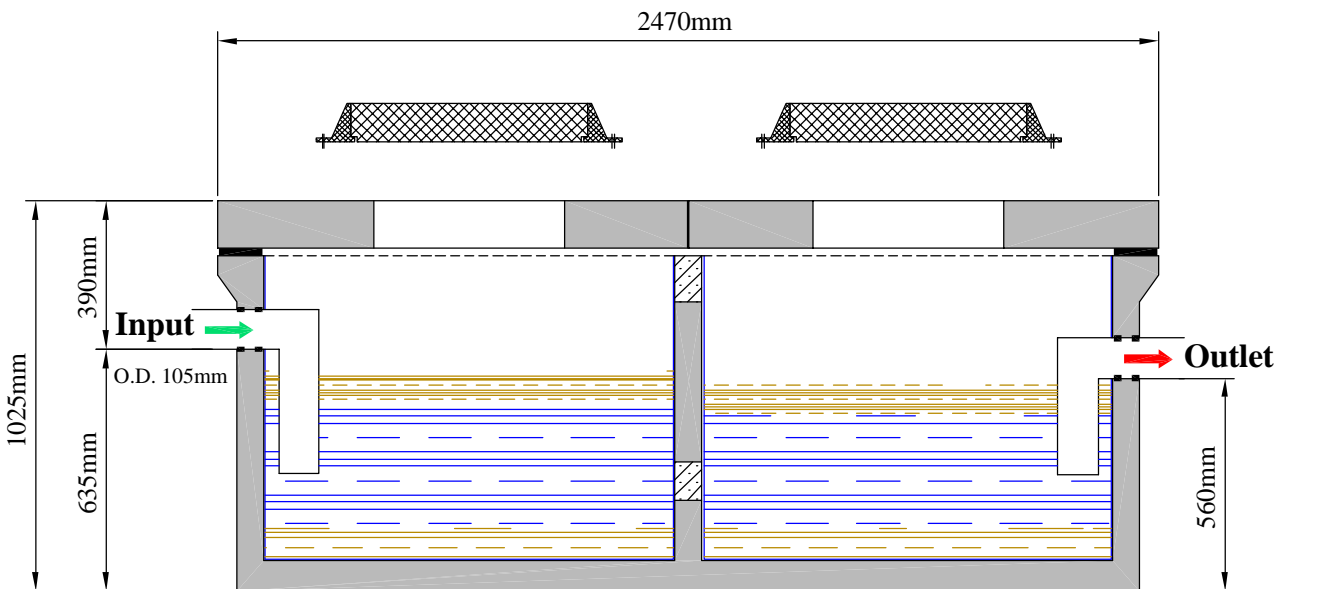

All tanks must be placed on a perfectly
 level and firm suitable base.

This drawing is ©. All rights reserved.

<p>E-mail: info@molloyprecast.com Web: www.molloyprecast.com</p> <p>Aswatrap from MOLLOY PRECAST</p>	<p>Molloy Precast Products Ltd. Coleraine, Clara Road, Tullamore, Co.Offaly. Tel: 05793 26000 Fax: 05793 26060</p>	<p>Grease Trap: FG-NS-4-00 Fats 7 Grease Trap designed to is EN 1825 Volume 1,450 lit.</p> <p>Tank Size: 2470mm x 1320mm Height: 1025mm Volume: 1450 liters Weight: 1500 Kg. (Tank Dim: ± 20mm. Weight: ± 30Kg.)</p>	<p>Note: See reverse for excavation details & safety regulations.</p> <p>Note: Specify hole drilling requirements. All civil works by customer.</p> <p>Note: Do NOT scale from drawings. Drawings for illustration purposes only.</p>
--	--	--	---