

TANK PLAN

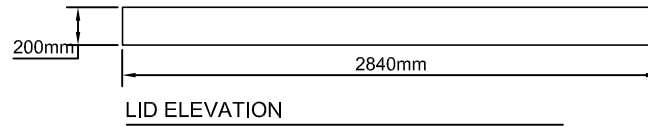

LID ELEVATION

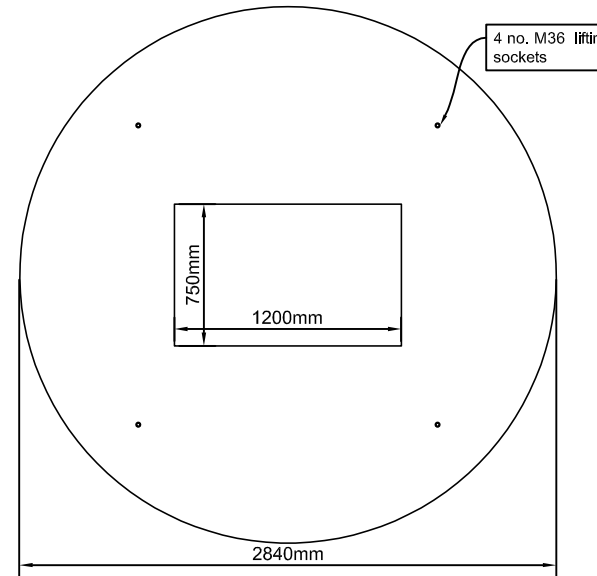

LID PLAN option 1: 1,200 X 750mm opening

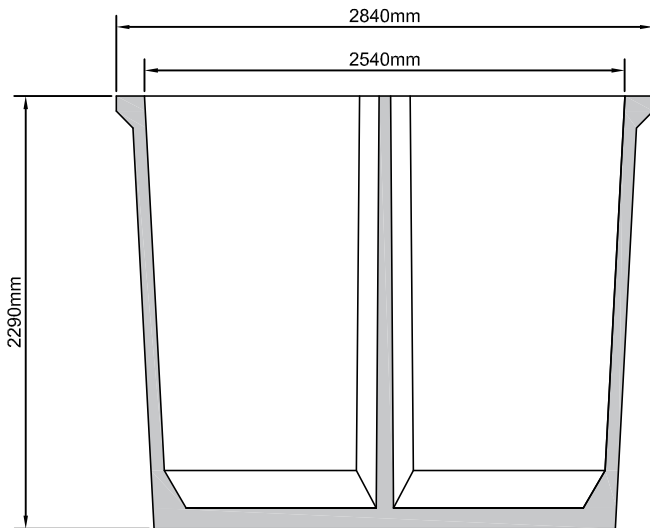

TANK SECTION through A-A

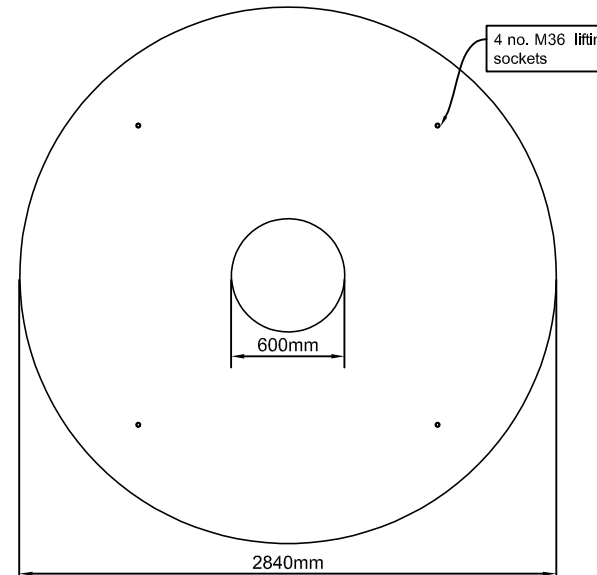

LID PLAN option 2: 600mm opening

Available Cores	Core size	Max invert from base
	63mm	2,050mm
	110mm (4")	2,000mm
	160mm (6")	2,950mm
	250mm (9")	1,870mm
	315mm (12")	1,800mm

Tank lifting limitations:
Max chain angle < 60°

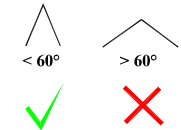

Damage caused by incorrect lifting is the responsibility of others

Notes:

- Observe all safety regulations in regard to excavation and lifting requirements. Never leave opening uncovered or unattended at any time
- Specify any specific requirements prior to ordering. All civil works by customer
- Do not scale from this drawing. Only for illustration purposes

MOLLOY
ENVIRONMENTAL SYSTEMS
Clara Rd., Tullamore, Co. Offaly
T: 057 9326000 E: info@molloyprecast.com
F: 057 9326060 W: www.molloyprecast.com



Title: L tank with a wall & lids drawing

Drg. no.: PT-LW-01-201118

Capacity: 10,000 litres

Weight: Tank - 5,600 kg

Lid, option 1: 2,535 kg

Lid, option 2: 2,845 kg

Date: 20/11/2018

Drawn by: SF Checked by: KR